

Operator's Manual

Lycoming

O-360 76 Series

Approved by FAA

2nd Edition

Part No. 60297-25

LYCOMING

652 Oliver Street
Williamsport, PA. 17701 U.S.A.
570/323-6181

June 2007

O-360 76 Series Operator's Manual

Lycoming Part Number: 60297-25

©2007 by Lycoming. All rights reserved.

Lycoming and "Powered by Lycoming" are trademarks or registered trademarks of Lycoming.

All brand and product names referenced in this publication are trademarks or registered trademarks of their respective companies.

For additional information:

Mailing address:

Lycoming Engines
652 Oliver Street
Williamsport, PA 17701 U.S.A.

Phone:

Factory: 570-323-6181
Sales Department: 570-327-7268
Fax: 570-327-7101

Lycoming's regular business hours are Monday through Friday from 8:00 AM through 5:00 PM Eastern Time (-5 GMT)

Visit us on the World Wide Web at:

<http://www.lycoming.com>



**OPERATOR'S MANUAL
REVISION**

REVISION NO.	PUBLICATION	PUBLICATION NO.	PUBLICATION DATE
60297-25-1	O-360 76 SERIES	60297-25	June 2007
The page(s) in this revision replace, add to, or delete current pages in the operator's manual.			
PREVIOUS REVISION		CURRENT REVISION	
None		August 2008 3-5, 3-7	

LYCOMING **76** SERIES OPERATOR'S MANUAL

ATTENTION

OWNERS, OPERATORS AND MAINTENANCE PERSONNEL

This operator's manual contains a description of the engine, its specifications, and detailed information on how to operate and maintain it. Such maintenance procedures that may be required in conjunction with periodic inspections are also included. This manual is intended for use by owners, pilots and maintenance personnel responsible for care of Lycoming powered aircraft. Modifications and repair procedures are contained in Lycoming overhaul manuals; maintenance personnel should refer to these for such procedures.

SAFETY WARNING

Neglecting to follow the operating instructions and to carry out periodic maintenance procedures can result in poor engine performance and power loss. Also, if power and speed limitations specified in this manual are exceeded, for any reason; damage to the engine and personal injury can happen. Consult your local FAA approved maintenance facility.

SERVICE BULLETINS, INSTRUCTIONS AND LETTERS

Although the information contained in this manual is up-to-date at time of publication, users are urged to keep abreast of later information through Lycoming Service Bulletins, Instructions and Service Letters which are available from Lycoming distributors or from the factory by subscription. Consult the latest revision of Service Letter No. L114 for subscription information.

SPECIAL NOTE

The illustrations, pictures and drawings shown in this publication are typical of the subject matter they portray; in no instance are they to be interpreted as examples of any specific engine, equipment or part thereof.

LYCOMING **76** SERIES OPERATOR'S MANUAL

IMPORTANT SAFETY NOTICE

Proper service and repair is essential to increase the safe, reliable operation of all aircraft engines. The service procedures recommended by Lycoming are effective methods for performing service operations. Some of these service operations require the use of tools specially designed for the task. These special tools must be used when and as recommended.

It is important to note that most Lycoming publications contain various Warnings and Cautions which must be carefully read in order to minimize the risk of personal injury or the use of improper service methods that may damage the engine or render it unsafe.

It is also important to understand that these Warnings and Cautions are not all inclusive. Lycoming could not possibly know, evaluate or advise the service trade of all conceivable ways in which service might be done or of the possible hazardous consequences that may be involved. Accordingly, anyone who uses a service procedure must first satisfy themselves thoroughly that neither their safety nor aircraft safety will be jeopardized by the service procedure they select.

LYCOMING **76** SERIES OPERATOR'S MANUAL

TABLE OF CONTENTS

		PAGE
SECTION 1	DESCRIPTION	1-1
SECTION 2	SPECIFICATIONS	2-1
SECTION 3	OPERATING INSTRUCTIONS	3-1
SECTION 4	PERIODIC INSPECTIONS	4-1
SECTION 5	MAINTENANCE PROCEDURES	5-1
SECTION 6	TROUBLE-SHOOTING	6-1
SECTION 7	INSTALLATION AND STORAGE	7-1
SECTION 8	TABLES	8-1

LYCOMING 76 SERIES OPERATOR'S MANUAL

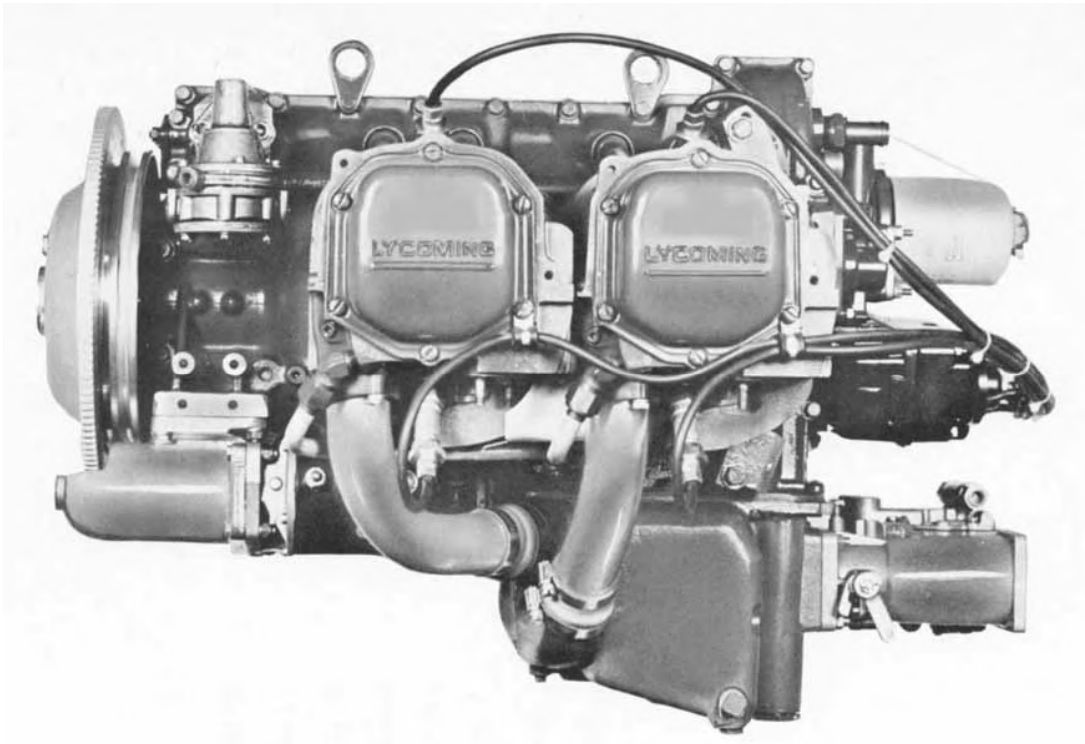

Left Side View – O-360 (76 Series)

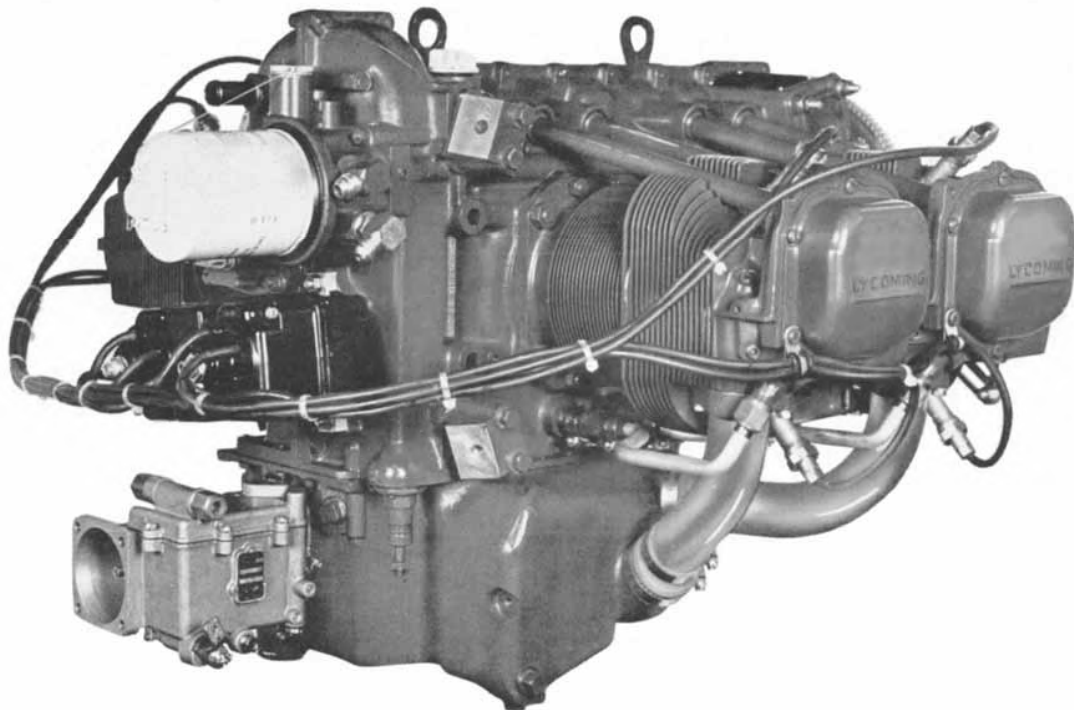

¾ Right Rear View – O-360 (76 Series)

LYCOMING **76** SERIES OPERATOR'S MANUAL

SECTION 1 DESCRIPTION

	Page
General.....	1-1
Cylinders.....	1-1
Valve Operating Mechanism	1-1
Crankcase	1-1
Crankshaft.....	1-1
Connecting Rods	1-2
Pistons	1-2
Oil Sump	1-2
Cooling System.....	1-2
Induction System.....	1-2
Lubrication System.....	1-2
Priming System	1-2

This Page Intentionally Left Blank.

SECTION 1

DESCRIPTION

General – The Lycoming O-360 “76 Series” aircraft engine is a four cylinder direct drive, horizontally opposed, wet sump, carbureted, air cooled engine.

In referring to the location of the various engine components, the parts are described in their relationship to the engine as installed in the airframe. Thus, the power take-off end is considered the front and accessory drive end the rear. The sump section is considered the bottom and the opposite side of the engine where the shroud tubes are located the top. References to the left and right side are made with the observer facing the rear of the engine. The cylinders are numbered from the front to the rear, the 1 and 3 cylinders are on the right side, 2 and 4 cylinders are on the left. The direction of rotation of the crankshaft is clockwise, viewed from the rear of the engine. The direction of rotation for the accessory drives is determined with the observer facing the drive pad.

NOTE

The letter “L” in the model prefix denotes the reverse rotation of the basic model. Example: O-360-E1AD has clockwise rotation of the crankshaft; therefore, LO-360-E1AD has a counterclockwise rotation. Likewise the rotations of the accessory drives of the LO-360-E1AD are opposite those of the basic model.

The letter “D” used as the 4th or 5th character in the model suffix denotes that the engine is equipped with a dual magneto housed in a single housing.

Operational aspects of engines are the same and performance data and specifications for the basic models will apply.

Cylinders – The cylinders are of conventional air cooled construction with two major parts, head and barrel, screwed and shrunk together. The heads are made from an aluminum alloy casting with a fully machined combustion chamber. The rocker box is cast as an integral part of the cylinder head which forms the housing from both intake and exhaust valve rockers. The cylinder barrels, which are machined from chrome nickel molybdenum steel forgings, have deep integral cooling fins and the inside of the barrels are ground and honed to a specified finish.

Valve Operating Mechanism – A conventional type camshaft is located above and parallel to the crankshaft. The camshaft actuates the hydraulic tappets which operate the valves through push rods and valve rockers. Valve rockers are held in place by the use of rocker arm fulcrum. The valve springs bear against hardened steel seats and are retained on the valve stems by means of split keys.

Crankcase – The crankcase assembly consists of two reinforced aluminum alloy castings with the accessory housing as an integral part, fastened together by means of studs, bolts and nuts. The mating surfaces of the two castings are joined without the use of gaskets and the main bearing bores are machined for the use of precision type main bearing inserts.

Crankshaft – The crankshaft is made from a chrome nickel molybdenum steel forging. All bearing journal surfaces are nitride hardened. Freedom from torsional vibration is assured by a system of pendulum type dynamic counterweights.

SECTION 1 DESCRIPTION

LYCOMING 76 SERIES OPERATOR'S MANUAL O-360

Connecting Rods – The connecting rods are made in the form of “H” sections from alloy steel forgings. They have replaceable bearing inserts in the crankshaft ends and bronze bushings in the piston ends. The bearing caps on the crankshaft ends are retained by two bolts and nuts through each cap.

Pistons – The pistons are machined from an aluminum alloy. The piston pin is of the floating type with a plug located at each end of the pin. The pistons employ half wedge rings. Consult the latest revision of Service Instruction No. 1037 for proper piston and ring combinations.

Oil Sump – The sump incorporates an oil drain plug, oil suction screen, mounting pad for the carburetor, the intake riser and the intake pipe connections.

Cooling System – The engine is designed to be air cooled by air pressure. Baffles are provided to build up a pressure and direct the air through the cylinder fins. The air is then exhausted to the atmosphere through the rear of the lower cowling.

Induction System – The engine is equipped with a Marvel-Schebler type HA-6 horizontal carburetor, equipped with a manual mixture control and idle cut-off. Distribution of the fuel air mixture is obtained through the center zone induction system, which is integral with the oil sump and is submerged in oil, insuring a more uniform vaporization of the fuel and aiding in cooling the oil in the sump. From the riser the fuel air mixture is distributed to each cylinder by individual intake pipes.

Lubrication System – The lubrication system is of the pressure wet sump type. The oil pump located on the exterior of the crankcase accessory section, draws oil through a drilled passage leading from the oil suction screen located in the sump. The oil from the pump then enters a drilled passage in the accessory section to the oil pressure screen housing where a flexible line leads the oil to the external oil cooler. In the event that cold oil or an obstruction should restrict the flow of oil to the cooler, an oil cooler bypass valve is provided. Pressure oil from the cooler returns to a second connection in the oil pressure screen housing from which point a drilled passage conducts the oil to the oil pressure relief valve, located at the bottom of the accessory section.

The pressure relief valve regulates the engine oil pressure by allowing the excessive oil to return to the sump, while the balance of the pressure oil is fed to the main oil gallery. The oil is distributed by means of a separate drilled passage to the main bearings of the crankshaft. Angular holes are drilled through the main bearing to the connecting rod journals. Oil from the main oil gallery also flows to the camshaft and valve gear passages and is then conducted through branch passages to the hydraulic tappets and camshaft bearing. Oil enters the tappets through indexing holes and travels out through the hollow push rod tubes to the valve mechanism, lubricating the valve rocker and valve stems. Residual oil from the bearings, accessory drives and rocker boxes is returned by gravity to the sump where after passing through a screen it is again circulated through the engine. Pressure build up within the crankcase is held to a minimum by means of a breather located on the top rear of the crankcase.

Priming System – Provision for a primer system is provided on all engines employing a carburetor.

LYCOMING 76 SERIES OPERATOR'S MANUAL

**SECTION 2
SPECIFICATIONS**

	Page
O-360-E	2-1
Standard Engine Weight	2-1
Accessory Drive	
Drive Ratio.....	2-1
Direction of Rotation	2-1

This Page Intentionally Left Blank.

**SECTION 2
SPECIFICATIONS**

O-360-E

FAA Type Certificate	286
Rated horsepower.....	180
Rated speed, RPM.....	2700
Bore, inches.....	5.125
Stroke, inches.....	4.375
Displacement, cubic inches.....	361.0
Compression ratio	9.0:1
Firing order	1-3-2-4
Spark occurs, degrees BTC.....	25°
Valve rocker clearance (hydraulic tappets collapsed)028-.080
Propeller drive ratio	1:1
Propeller drive rotation (viewed from rear).....	Clockwise

Standard Dry Weight

O-360-E1AD, -E2AD, -E1BD, -E2BD.....	293 lbs.
--------------------------------------	----------

*Accessory Drive	Drive Ratio	**Direction of Rotation
Starter	16.550:1	Counterclockwise
Alternator	3.250:1	Clockwise
Tachometer Drive	0.500:1	Clockwise
Magneto	1.000:1	Clockwise
AN Vacuum Pump Drive	1.313:1	Counterclockwise
Propeller Gov. AN-20010	1.000:1	Clockwise
Dual Drive		
Vacuum Pump and Hyd. Pump	1.313:1	Counterclockwise

* - When applicable.

** - Viewed facing drive pad. Note that engines with "L" in prefix will have opposite rotation to the above.

This Page Intentionally Left Blank

LYCOMING 76 SERIES OPERATOR'S MANUAL

**SECTION 3
OPERATING INSTRUCTIONS**

	Page
General.....	3-1
Prestarting Items of Maintenance	3-1
Starting Procedures	3-1
Cold Weather Starting	3-2
Ground Running and Warm-Up	3-2
Ground Check	3-3
Operation in Flight	
Leaning Procedure.....	3-4
Use of Intake Air Heat Control.....	3-5
Engine Flight Chart	3-7
Engine Shut-Down Procedure	3-9
Performance Curves	3-10

This Page Intentionally Left Blank.

SECTION 3
OPERATING INSTRUCTIONS

1. *GENERAL.* Close adherence to these instructions will greatly contribute to long life, economy and satisfactory operation of the engine.

NOTE

YOUR ATTENTION IS DIRECTED TO THE WARRANTIES THAT APPEAR IN THE FRONT OF THIS MANUAL REGARDING ENGINE SPEED, THE USE OF SPECIFIED FUELS AND LUBRICANTS, REPAIRS AND ALTERATIONS. PERHAPS NO OTHER ASPECT OF ENGINE OPERATION AND MAINTENANCE CONTRIBUTES QUITE SO MUCH TO SATISFACTORY PERFORMANCE AND LONG LIFE AS THE CONSTANT USE OF CORRECT GRADES OF FUEL AND OIL, CORRECT ENGINE TIMING, AND FLYING THE AIRCRAFT AT ALL TIMES WITHIN THE SPEED AND POWER RANGE SPECIFIED FOR THE ENGINE. DO NOT FORGET THAT VIOLATION OF THE OPERATION AND MAINTENANCE SPECIFICATIONS FOR YOUR ENGINE WILL NOT ONLY VOID YOUR WARRANTY BUT WILL SHORTEN THE LIFE OF YOUR ENGINE AFTER ITS WARRANTY PERIOD HAS PASSED.

New engines have been carefully run-in by Lycoming and therefore, no further break-in is necessary insofar as operation is concerned; however, new or newly overhauled engines should avoid low power below 65% during the first 50 hours or until the oil consumption has stabilized. The engine should also be operated on straight mineral oil for a minimum of 50 hours or until the oil consumption has stabilized. After this period a change to an approved additive oil Spec. MIL-L-6082 or Ashless Dispersant MIL-L-22851 may be made, if so desired.

NOTE

Cruising should be done at 65% to 75% power until a total of 50 hours has accumulated or oil consumption has stabilized. This is to ensure proper seating of the rings and is applicable to new engines, and engines in service following cylinder replacement or top overhaul of one or more cylinders.

The minimum fuel octane rating is listed in the flight chart, Part 9, of this section. Under no circumstances should fuel of a lower octane rating or automotive fuel (regardless of octane rating) be used.

2. *PRESTARTING ITEMS OF MAINTENANCE.* Before starting the aircraft engine for the first flight of the day, there are several items of maintenance inspection that should be performed. These are described in Section 4 under Daily Pre-Flight Inspection. They must be observed before the engine is started.

3. *STARTING PROCEDURES.*

The following starting procedures are recommended; however, the starting characteristics of various installations will necessitate some variation from these procedures.

NOTE

Cranking periods must be limited to ten (10) to twelve (12) seconds with a five (5) minute rest between cranking periods.

a. Carbureted Engines (Cold).

- (1) Perform pre-flight inspection.
- (2) Set carburetor heat control in "off" position.
- (3) Set propeller governor control in "Full Rich" position (where applicable).
- (4) Turn fuel valves "On".
- (5) Move mixture control to "Full RPM".
- (6) Turn boost pump on (where applicable).
- (7) Open throttle approximately ¼ travel.
- (8) Prime with 1 to 3 strokes of manual priming pump or activate electric primer for 1 or 2 seconds.
- (9) Set magneto selector switch. (Consult airframe manufacturer's handbook for correct position.)
- (10) Engage starter.
- (11) When engine fires move the magneto switch to "Both".
- (12) Check oil pressure gauge. If minimum oil pressure is not indicated within thirty seconds, stop engine and determine trouble.

NOTE

If engine fails to achieve a normal start, assume it to be flooded and use standard clearing procedure, then repeat above steps.

b. Carbureted Engines (Hot) – Proceed as outlined above, omitting the priming step.

4. COLD WEATHER STARTING. During extreme cold weather, it may be necessary to preheat the engine and oil before starting.

5. GROUND RUNNING AND WARM-UP.

The engines covered in this manual are air pressure cooled and depend on the forward speed of the aircraft to maintain proper cooling. Particular care is necessary, therefore, when operating these engines on the ground. To prevent overheating, it is recommended that the following precautions be observed.

NOTE

Any ground check that requires full throttle operation must be limited to three minutes, or less if the indicated cylinder head temperatures should exceed the maximum stated in this manual.

- a. Head the aircraft into the wind.
- b. Leave mixture in "Full Rich".
- c. Operate only with the propeller in minimum blade angle setting (where applicable).
- d. Warm up at approximately 1000-1200 RPM. Avoid prolonged idling and do not exceed 2200 RPM on the ground.
- e. Engine is warm enough for take-off when the throttle can be opened without the engine faltering.

6. GROUND CHECK.

- a. Warm-up as directed above.
- b. Check both oil pressure and oil temperature.
- c. Leave mixture in "Full Rich".
- d. (Where applicable.) Move the propeller control through its complete range to check operation and return it to full low pitch position. Full feathering check (twin engine) on the ground is not recommended but the feathering action can be checked by running the engine between 1000-1500 RPM; then momentarily pulling the propeller control into the feathering position. Do not allow the RPM to drop more than 500 RPM.
- e. A proper magneto check is important. Additional factors, other than the ignition system, affect magneto drop-off. They are load power output, propeller pitch and mixture strength. The important thing is that the engines run smoothly because magneto drop-off is affected by the variables listed above. Make the magneto check in accordance with the following procedures.
 - (1) *Controllable Pitch Propeller* – With propeller in minimum pitch angle, set the engine to produce 50-65% power as indicated by the manifold pressure gauge. Mixture control should be in the full rich position. At these settings, the ignition system and spark plugs must work harder because of the greater pressure within the cylinders. Under these conditions ignition problems, if they exist, will occur. Magneto checks at lower power settings will only indicate fuel-air distribution quality.

NOTE

Aircraft that are equipped with fixed pitch propellers, or not equipped with manifold pressure gauge, may check magneto drop-off with engine operating at a minimum of 2000-2100 RPM.

- (2) Switch from both magnetos to one and note drop-off, return to both until engine regains speed and switch to the other magneto and note drop-off, then return to both. Drop-off should not exceed 175 RPM and should not exceed 50 RPM between magnetos. A smooth drop-off past normal is usually a sign of a too lean or too rich mixture.
- f. Do not operate on a single magneto for too long a period, a few seconds is usually sufficient to check drop-off and will minimize the possibility of plug fouling.

7. OPERATION IN FLIGHT.

See airframe manufacturer's instructions for recommended power settings.

a. Fuel Mixture Leaning Procedure.

Improper fuel/air mixture during flight is responsible for many engine problems, particularly during take-off and climb power settings. The procedures described in this manual provide proper fuel/air mixture when leaning Lycoming engines; they have proven to be both economical and practical by eliminating excessive fuel consumption and reducing damaged parts replacement. It is therefore recommended that operators of all Lycoming aircraft power plants utilize the instructions in this publication any time the fuel/air mixture is adjusted during flight.

Manual leaning may be monitored by exhaust gas temperature indication, fuel flow indication, and by observation of engine speed and/or air speed. However, whatever instruments are used in monitoring the mixture, the following general rules should be observed by the operator of Lycoming aircraft engines.

GENERAL RULES

Never exceed the maximum red line cylinder head temperature of 500°F (260°C).

For maximum service life, cylinder head temperatures should be maintained below 435°F (224°C) during high performance cruise operation and below 400°F (205°C) for economy cruise powers.

Never lean the mixture from full rich during take-off, climb or high performance cruise operation unless the airplane owners manual advises otherwise. However, during take-off from high elevation airports or during climb at higher altitudes, roughness or reduction of power may occur at full rich mixture. In such a case the mixture may be adjusted only enough to obtain smooth engine operation. Careful observation of temperature instruments should be practiced.

Operate the engine at maximum power mixture for performance cruise powers and at best economy mixture for economy cruise power; unless otherwise specified in the airplane owners manual.

Always return the mixture to full rich before increasing power settings.

During let down and reduced power flight operations it may be necessary to manually lean or leave mixture setting at cruise position prior to landing. During the landing sequence the mixture control should then be placed in the full rich position, unless landing at high elevation fields where leaning may be necessary.

a. LEANING WITH EXHAUST GAS TEMPERATURE GAUGE

- (1) *Maximum Power Cruise (approximately 75% power)* – It is permissible to lean to 100°-150°F on rich side of peak EGT unless aircraft operator's manual shows otherwise. Monitor cylinder head temperatures.
- (2) *Best Economy Cruise (approximately 75% power and below)* – Operate at peak EGT.

b. LEANING WITH FLOWMETER.

Lean to applicable fuel flow tables or lean to indicator marked for correct fuel flow for each power setting.

c. LEANING WITH MANUAL MIXTURE CONTROL (Economy Cruise, 75% power or less – without flowmeter or EGT gauge).

- (1) Slowly move mixture control from "Full Rich" position toward lean position.
- (2) Continue leaning until engine roughness is noted.
- (3) Enrich until engine runs smoothly and power is regained.



WARNING

REFER TO THE PILOT'S OPERATING HANDBOOK OR AIRFRAME MANUFACTURER'S MANUAL FOR ADDITIONAL INSTRUCTIONS ON THE USE OF CARBURETOR HEAT CONTROL. INSTRUCTIONS FOUND IN EITHER PUBLICATION SUPERSEDE THE FOLLOWING INFORMATION.

8. USE OF CARBURETOR HEAT CONTROL. Under certain moist atmospheric conditions (generally at a relative humidity of 50% or greater) and at temperatures of 20° to 90°F it is possible for ice to form in the induction system. Even in summer weather ice may form. This is due to the high air velocity through the carburetor venturi and the absorption of heat from this air by vaporization of the fuel. The temperature in the mixture chamber may drop as much as 70°F below the temperature of the incoming air. If this air contains a large amount of moisture, the cooling process can cause precipitation in the form of ice. Ice formation generally begins in the vicinity of the butterfly and may build up to such an extent that a drop in power output could result. In installations equipped with fixed pitch propellers, a loss of power is reflected by a drop in manifold pressure and RPM. In installations equipped with constant speed propellers, a loss of power is reflected by a drop in manifold pressure. If not corrected, this condition may cause complete engine stoppage.

To avoid this, all installations are equipped with a system for preheating the incoming air supply to the carburetor. In this way sufficient heat is added to replace the heat loss of vaporization of fuel, and the mixing chamber temperature cannot drop to the freezing point of water (32°F). The air preheater is a tube or jacket through which the exhaust pipe from one or more cylinders is passed, and the air flowing over these surfaces is raised to the required temperature before entering the carburetor. Consistently high temperatures are to be avoided because of a loss of power and a decided variation of mixture. High charge temperatures also favor detonation and preignition, both of which are to be avoided if normal service life is to be expected from the engine. The following outline is the proper method of utilizing the carburetor heat control.

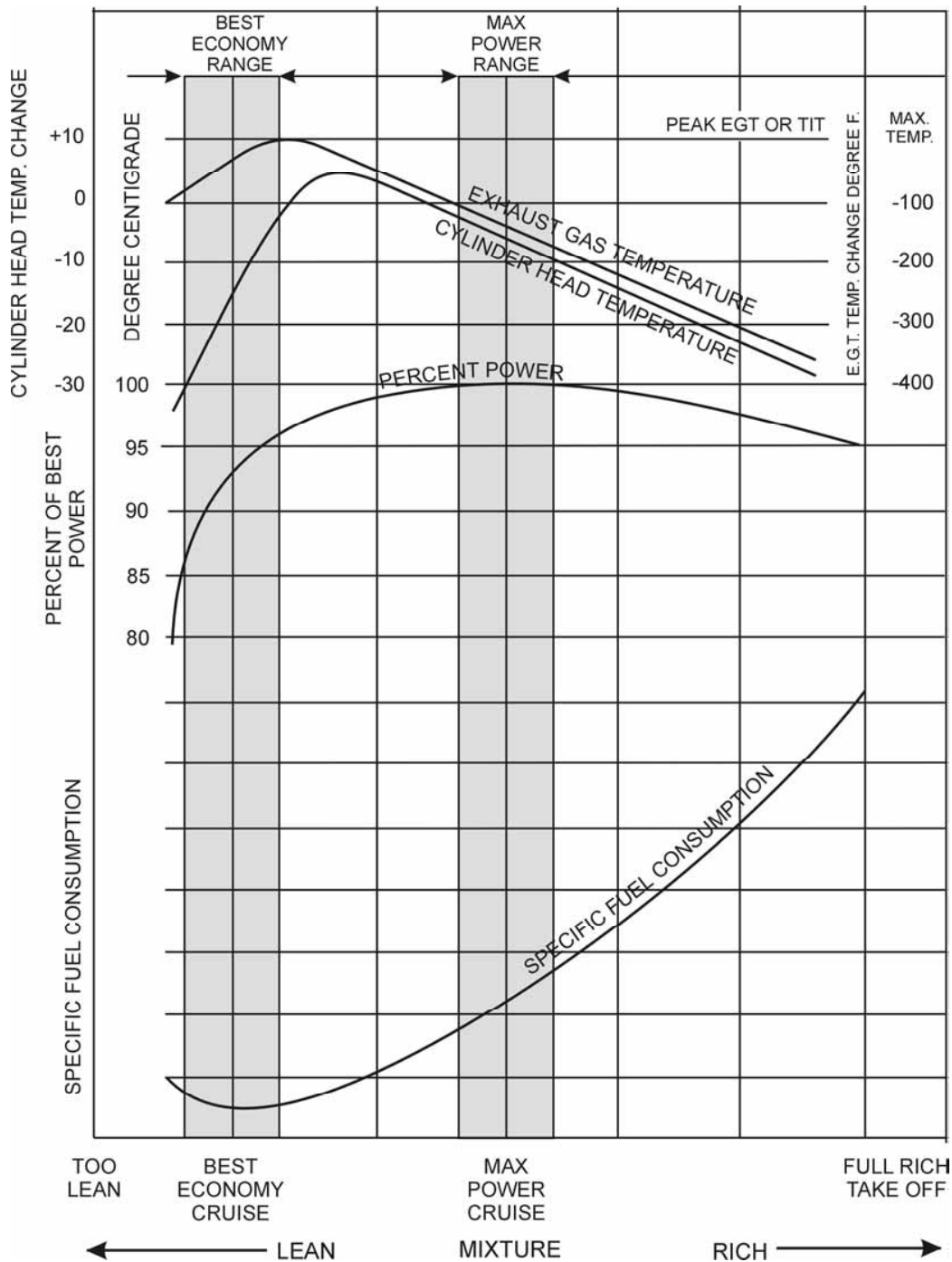

Figure 3-1. Representative Effect of Leaning on Cylinder Head Temperature, EFT (Exhaust Gas Temperature), Engine Power and Specific Fuel Consumption at Constant Engine RPM and Manifold Pressure

- a. *Ground Operation* – Use of the carburetor air heat on the ground must be held to an absolute minimum. On some installations the air does not pass through the air filter, and dirt and foreign substances can be taken into the engine with the resultant cylinder and piston ring wear. Only use carburetor air heat on the ground to make certain it is functioning properly.
- b. *Take-Off* – Set the carburetor heat in full cold position. For take-off and full throttle operation the possibility of expansion or throttle icing at wide throttle openings is very remote.
- c. *Climbing* – When climbing at part throttle power settings of 80% or above, set the carburetor heat control in the full cold position; however, if it is necessary to use carburetor heat to prevent icing it is possible for engine roughness to occur due to the over-rich fuel/air mixture produced by the additional carburetor heat. When this happens, lean the mixture with the mixture control only enough to produce smooth engine operation. Do not continue to use carburetor heat after flight is out of icing conditions, and return mixture to full rich when carburetor heat is removed.
- d. *Flight Operation* – During normal flight, leave the carburetor air heat control in the full cold position. On damp, cloudy, foggy or hazy days, regardless of the outside air temperature, be alert for loss of power. This will be evidenced by an unaccountable loss in manifold pressure or RPM or both, depending on whether a constant speed or fixed pitch propeller is installed on the aircraft. If this happens, apply full carburetor air heat and open the throttle to limiting manifold pressure and RPM. This will result in a slight additional drop in manifold pressure, which is normal, and this drop will be regained as the ice is melted out of the induction system. When ice has been melted from the induction system, return the carburetor heat control to the full cold position. In those aircraft equipped with a carburetor air temperature gauge, partial heat may be used to keep the mixture temperature above the freezing point of water (32°F).



WARNING

CAUTION MUST BE EXERCISED WHEN OPERATING WITH PARTIAL HEAT ON AIRCRAFT THAT DO NOT HAVE A CARBURETOR AIR TEMPERATURE GAUGE. USE EITHER FULL HEAT OR NO HEAT IN AIRCRAFT THAT ARE NOT EQUIPPED WITH A CARBURETOR AIR TEMPERATURE GAUGE.

- e. *Landing Approach* – In making a landing approach, the carburetor heat is generally in the “Full Cold” position. However, if icing conditions are suspected, apply “Full Heat”. In the case that full power need to be applied under these conditions, as for an aborted landing, return the carburetor heat to “Full Cold” after full power application.

9. ENGINE FLIGHT CHART.

FUEL AND OIL –

Model	*Aviation Grade Fuel Minimum
O-360-E.....	100/130

NOTE

Aviation grade 100LL fuels in which the lead content is limited to 2 c.c. per gallon are approved for continuous use in these engines.

* - Refer to latest revision of Service Instruction No. 1070.

**SECTION 3
OPERATING INSTRUCTIONS**

Fuel Pressure, psi –

Model	Max.	Desired	Min.
O-360-E Inlet to carburetor	8.0	3.0	0.5

Fuel Consumption (Gal. per Hour) –

O-360-E

Normal Rated (2700 RPM, 180 HP).....	14.9
75% Rated (2400 RPM, 135 HP).....	10.8
65% Rated (2350 RPM, 117 HP).....	8.8

Lubrication Oil –

*Recommended Grade Oil

Average Ambient Air	MIL-L-6082 Grades	MIL-L-22851 Ashless Dispersant Grades
Above 60°F	SAE 50	SAE 40 or SAE 50
30° to 90°F	SAE 40	SAE 40
0° to 70°F	SAE 30	SAE 40 or SAE 30
Below 10°F	SAE 20	SAE 30

* - See latest revision of Service Instruction No. 1014 for complete lubrication oil recommendations.

*Oil Inlet Temperature

Average Ambient Air	Desired	Maximum
Above 60°F	180°F (82°C)	245°F (118°C)
30°F to 90°F	180°F (82°C)	245°F (118°C)
0°F to 70°F	170°F (77°C)	225°F (107°C)
Below 10°F	160°F (71°C)	210°F (99°C)

* - Engine oil temperature should not be below 140F (60°C) during continuous operation.

Oil Sump Quantities –

O-360-E

Minimum safe quantity in sump	2 qts, (U.S.)
Maximum sump capacity	6 qts. (U.S.)

Oil Pressure, psi –

	Max.	Min.*	Idling
Normal Operation	90	60	15
Starting and Warm-Up	100		

* - See Section 5, Page 5-6 for oil pressure relief valve adjustment.

Oil Consumption –

	Max. Oil Cons. Qts. Per Hour
O-360-E	
Normal Rated (2700 RPM, 180 HP).....	80
75% Rated (2450 RPM, 135 HP).....	45
65% Rated (2350 RPM, 117 HP).....	39

Cylinder Head Temperature –

Maximum permissible500°F (260°C)

NOTE

Cylinder head temperature taken at the Baronet Location. For maximum service life of the engine, maintain cylinder head temperatures between 150°F (66°C) and 400°F (205°C) during continuous operation.

10. ENGINE SHUT-DOWN.

- a. Set propeller at minimum blade angle (where applicable).
- b. Idle until there is a decided decrease in cylinder head temperatures.
- c. Move mixture control to the idle cut-off position.
- d. When engine stops, turn ignition switch to off position.

FUEL FLOW VS PERCENT RATED POWER LYCOMING O-360-E SERIES

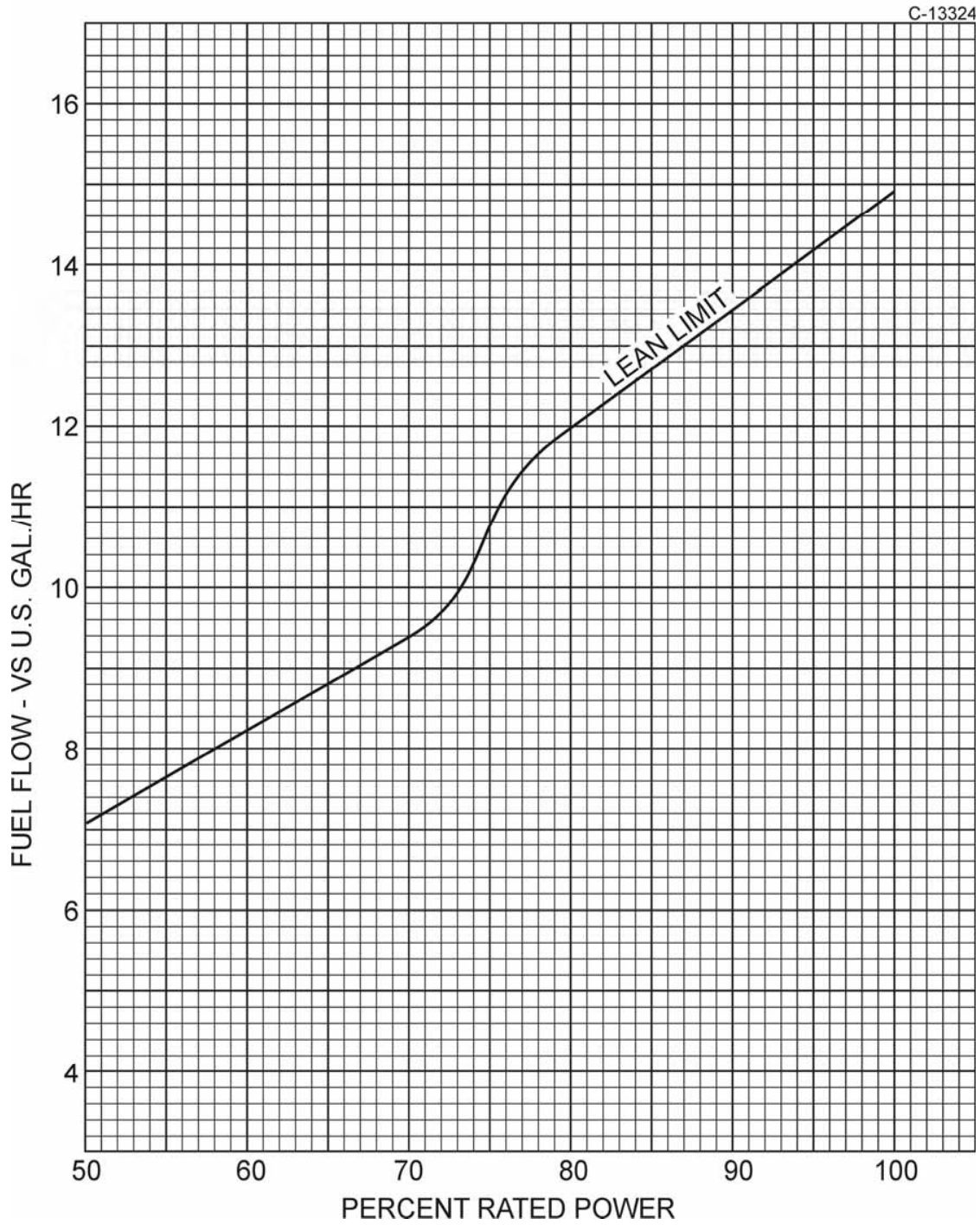

Figure 3-2. Fuel Flow vs Percent Rated Power – O-360-E

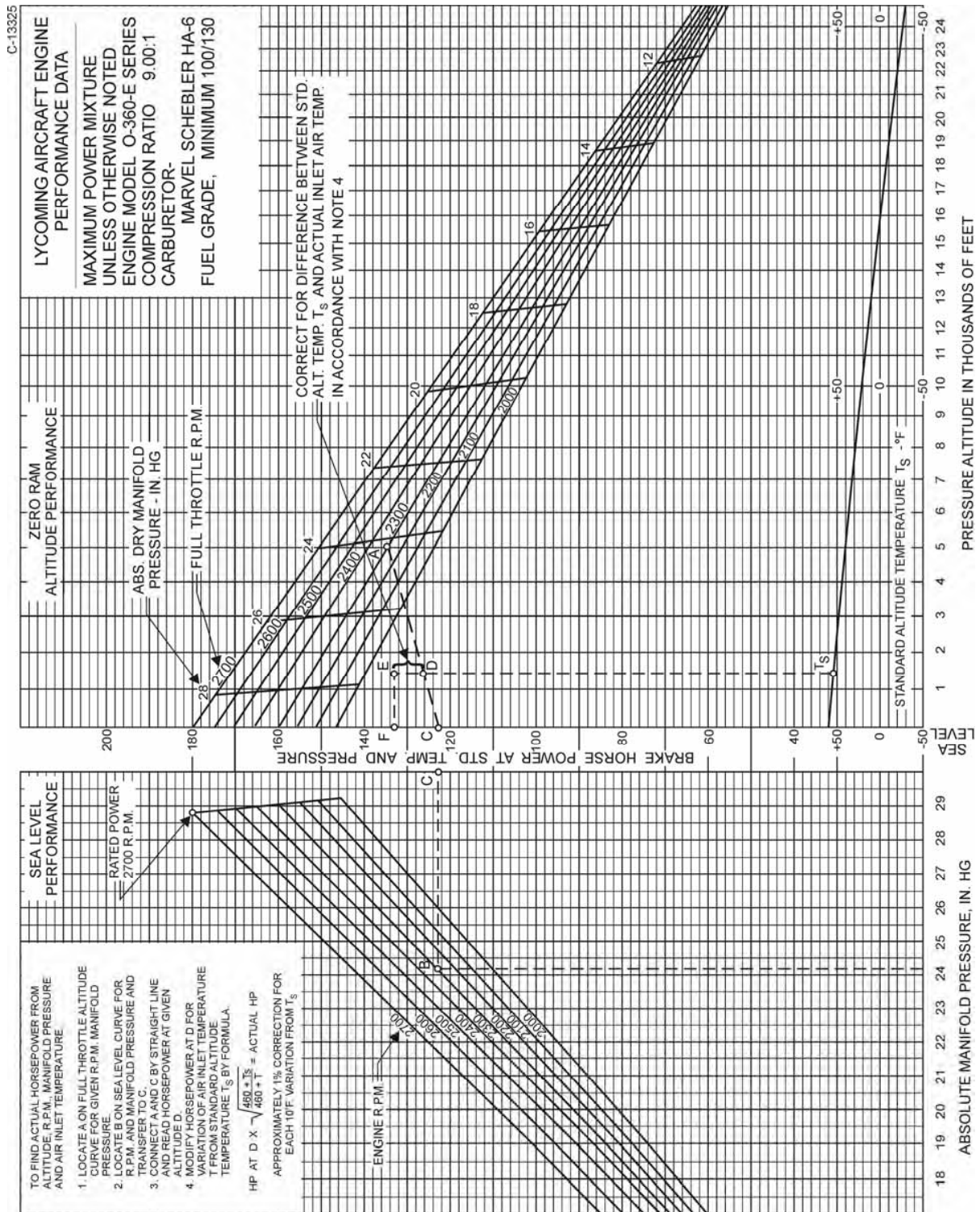

Figure 3-3. Sea Level and Altitude Performance – O-360-E

This Page Intentionally Left Blank.

LYCOMING 76 SERIES OPERATOR'S MANUAL

**SECTION 4
PERIODIC INSPECTIONS**

	Page
General.....	4-1
Pre-Starting Inspection	4-1
Daily Pre-Flight.....	4-2
25-Hour Inspection	4-2
50-Hour Inspection	4-2
100-Hour Inspection	4-3
400-Hour Inspection	4-4
Non-Scheduled Inspections	4-4

This Page Intentionally Left Blank.

SECTION 4
PERIODIC INSPECTIONS

NOTE

Perhaps no other factor is quite so important to safety and durability of the aircraft and its components as faithful and diligent attention to regular checks for minor troubles and prompt repairs when they are found.

The operator should bear in mind that the items listed in the following pages do not constitute a complete aircraft inspection, but are meant for the engine only. Consult the airframe manufacturer's handbook for additional instructions.

Pre-Starting Inspection – The daily pre-flight inspection is a check of the aircraft prior to the first flight of the day. This inspection is to determine the general condition of the aircraft and engine.

The importance of proper pre-flight inspection cannot be over emphasized. Statistics prove several hundred accidents occur yearly directly responsible to poor pre-flight inspections.

Among the major causes of poor pre-flight inspection are lack of concentration, reluctance to acknowledge the need for a check list, carelessness bred by familiarity and haste.

SECTION 4
PERIODIC INSPECTIONS

LYCOMING 76 SERIES OPERATOR'S MANUAL
O-360

1. DAILY PRE-FLIGHT.

- a. Be sure all switches are in the "off" position.
- b. Be sure magneto ground wires are properly connected.
- c. Check oil level.
- d. See that fuel tanks are full.
- e. Check fuel and oil line connections, note any minor indications for repair at 50-hour inspection. Repair any leaks before the aircraft is flown.
- f. Open the fuel drain to remove any accumulation of water and sediment.
- g. Make sure all shields and cowling are in place and secure. If any are missing or damaged, repair or replacement should be made before the aircraft is flown.
- h. Check all controls for general condition, travel and freedom of operation.
- i. Inspect the induction system air filter and service in accordance with the airframe manufacturer's recommendations.

2. 25-HOUR INSPECTION. After the first twenty-five hours operating time; new, rebuilt or newly overhauled engines should undergo a 50-hour inspection, including draining and renewing the lubricating oil.

3. 50-HOUR INSPECTION. In addition to the items listed for daily pre-flight inspection, the following maintenance checks should be made after every 50 hours of operation.

a. Ignition System –

- (1) If fouling of spark plugs has been apparent, rotate bottom plugs to top position.
- (2) Examine spark plug leads of cable and ceramics for corrosion and deposits. This condition is evidence of either leaking spark plugs, improper cleaning of the spark plug walls or connector ends. Where this condition is found, clean the cable ends, spark plug walls and ceramics with a dry, clean cloth or a clean cloth moistened with methyl-ethy-ketone. All parts should be clean and dry before reassembly.
- (3) Check ignition harness for security of mounting clamps and be sure connections are tight at spark plug and magneto terminals.

b. Fuel and Induction System – Check the primer lines for leaks and security of the clamps. Remove and clean the fuel inlet strainers. Check the mixture control and throttle linkage for travel, freedom of movement, security of the clamps and lubricate if necessary. Check the air intake ducts for leaks, security, filter damage; evidence of dust or other solid material in the ducts is indicative of inadequate filter care or damaged filter. Check vent lines for evidence of fuel or oil seepage; if present, fuel pump may require replacement.

c. *Lubrication System* –

- (1) Remove oil suction screen and check carefully for presence of metal particles that are indicative of internal engine damage. This step is not feasible unless oil is being changed and should be omitted on installations employing an external full flow oil filter.
- (2) Replace external full flow oil filter element. Examine the filter element for metal particles or carbon contamination. Drain and renew lubricating oil on installations not employing external full flow oil filter.

NOTE

Intervals between oil changes can be increased as much as 100% on engines equipped with full flow oil filters – provided the element is replaced each 50 hours of operation. However, the use of high lead content fuel, the operation in dusty areas, cold climates, and where short flight and long idle periods are encountered, more frequent oil changes may be necessary.

- (3) Check oil lines for leaks, particularly at connections and for security at clamp location. Also check for wear due to rubbing or vibration, for dents and cracks.

- d. *Exhaust System* – Check attaching flanges at exhaust ports on cylinder for evidence of leakage. If they are loose, they must be removed and machined flat before they are reassembled and tightened. Examine exhaust manifolds, muffler, and pipes, leakage and loose connections. Repair or replace as necessary.
- e. *Cooling System* – Check cowling and baffles for damage and secure anchorage. Any damaged or missing part of the cooling system must be repaired or replaced before the aircraft resumes operation.
- f. *Cylinders* – Check rocker box covers for evidence of oil leaks. If found, replace gasket and tighten screws to specified torque (50 in.-lbs.).

Check cylinders for evidence of excessive heat which is indicated by burned paint on the cylinder. This condition is indicative of internal damage to the cylinder and, if found, its cause must be determined and corrected before the aircraft resumes operation.

Heavy discoloration and appearance of seepage at cylinder head and barrel attachment area is usually due to emission of thread lubricant used during assembly of the barrel at the factory, or by slight gas leakage which stops after the cylinder has been in service for awhile. This condition is neither harmful nor detrimental to engine performance and operation. If it can be proven that leakage exceeds these conditions, the cylinder should be replaced. However, if the seepage or gas leakage continues it will be necessary to replace the cylinder and head assembly.

4. 100-HOUR INSPECTION. In addition to the items listed for daily pre-flight and 50-hour inspection, the following maintenance checks should be made after every one hundred hours of operation.

a. *Electrical System* –

- (1) Check all wiring connected to the engine or accessories. Any shielded cables that are damaged should be replaced. Replace clamps or loose wires and check terminals for security and cleanliness.

(2) Remove spark plugs; test, clean and regap. Replace if necessary.

- b. *Magnetos* – Check breaker points for pitting and minimum gap. Check for excessive oil in the breaker compartment, if found, wipe dry with a clean lint free cloth. The felt located at the breaker points should be lubricated in accordance with the magneto manufacturer's instructions. Check magneto to engine timing. Timing procedure is described in Section 5, 1, b of this manual.
- c. *Engine Accessories* – Engine mounted accessories such as pumps, temperature and pressure sensing units should be checked for secure mounting, tight connections.
- d. *Cylinders* – Check cylinders visually for cracked or broken fins.
- e. *Engine Mounts* – Check the engine mounting bolts and bushings for security and excessive wear. Replace any bushings that are excessively worn.

5. *400-HOUR INSPECTION*. In addition to the items listed for daily pre-flight, 50-hour and 100-hour inspections, the following maintenance check should be made after every 400 hours of operation.

Valve Inspection – Remove rocker box covers and check for freedom of valve rockers when valves are closed. Look for evidence of abnormal wear or broken parts in the area of the valve tips, valve keeper, springs and spring seats. If any indications are found, the cylinder and all of its components should be removed (including the piston and connecting rod assembly) and inspected for further damage. Replace any parts that do not conform with limits shown in the latest revision of Special Service Publication No. SSP-1776.

6. *NON-SCHEDULED INSPECTIONS*. Occasionally, service bulletins or service instructions are issued by Lycoming that require inspection procedures that are not listed in this manual. Such publications usually are limited to specified engine models and become obsolete after corrective modification has been accomplished. All such publications are available from Lycoming distributors, or from the factory by subscription. Consult the latest revision of Service Letter No. L114 for subscription information. Maintenance facilities should have an up-to-date file of these publications available at all times.

LYCOMING 76 SERIES OPERATOR'S MANUAL

SECTION 5 MAINTENANCE PROCEDURES

	Page
General.....	5-1
Ignition and Electrical System	
Ignition Harness and Wire Replacement.....	5-1
Timing Magnetos to Engine	5-1
Internal Timing – Dual Magneto.....	5-2
Alternator Output.....	5-4
Fuel System	
Repair of Fuel Leaks.....	5-4
Carburetor Fuel Inlet Screen Assembly	5-4
Fuel Grades and Limitations	5-4
Air Intake Ducts and Filter	5-5
Idle Speed and Mixture Adjustment.....	5-5
Lubrication System	
Oil Grades and Limitations.....	5-5
Oil Suction and Oil Pressure Screens	5-5
Oil Relief Valve Adjustment	5-6
Cylinders.....	5-6
Alternator Drive Belt Tension	5-9

This Page Intentionally Left Blank.

SECTION 5

MAINTENANCE PROCEDURES

The procedures described in this section are provided to guide and instruct personnel in performing such maintenance operations that may be required in conjunction with the periodic inspections listed in the preceding section. No attempt is made to include repair and replacement operations that will be found in the applicable Lycoming Overhaul Manual.

1. IGNITION AND ELECTRICAL SYSTEM.

a. Ignition Harness and Wire Replacement – In the event that an ignition harness or an individual lead is to be replaced, consult the wiring diagram to be sure harness is correctly installed. Mark location of clamps and clips to be certain the replacement is clamped at correct locations.

b. Timing Magneto to Engine –

- (1) Remove a spark plug from No. 1 cylinder and place a thumb over the spark plug hole. Rotate the crankshaft in direction of normal rotation until the compression stroke is reached, this is indicated by a positive pressure inside the cylinder tending to push the thumb off the spark plug hole. Continue rotating the crankshaft until the advance timing mark on the front face of the starter ring gear is in alignment with the small hole located at the two o'clock position on the front face of the starter housing. (Ring gear may be marked at 20° and 25°. Consult specifications for correct timing mark for your installation.) At this point, the engine is ready for assembly of the magneto.

c. Dual Magneto –

- (1) Place the engine in the No. 1 firing position as directed in paragraph 1b(1).
- (2) Install the magneto-to-engine gasket on the magneto flange.

WARNING

DO NOT ATTACH HARNESS SPARK PLUG ENDS TO THE SPARK PLUGS UNTIL ALL MAGNETO-TO-ENGINE TIMING PROCEDURES AND MAGNETO-TO-SWITCH CONNECTIONS ARE ENTIRELY COMPLETED.

- (3) Remove engine-to-magneto drive gear train backlash by turning engine magneto drive in direction opposite to normal rotation and return to timing mark on the starter support in direction of normal rotation.
- (4) Remove the timing window plug from the most convenient side of the magneto housing and the plug from the rotor viewing location in the center of the housing.
- (5) Turn the rotating magnet drive shaft in the normal direction of magneto rotation until the painted tooth of the large distributor gear is centered in the timing hole.
- (6) Observe that at this time the built in pointer just ahead of the rotor viewing window aligns with the R or L mark on the rotor depending on whether the magneto is of right or left hand rotation as specified on the magneto nameplate.

- (7) Hold the magneto in its No. 1 firing position (tooth in window center and pointer over R or L mark on rotor) and install magneto to the engine and loosely clamp in position.
- (8) Attach red lead from the timing light to left switch adapter lead, green lead of timing light to right switch adapter lead and the black lead of the light to magneto housing.
- (9) Turn the entire magneto in direction of rotor rotation until the red timing light comes on.
- (10) Rotate the magneto in the opposite direction until the red light just goes off indicating left main breaker has opened. Then evenly tighten the magneto mounting clamps.
- (11) Back the engine up approximately 10° and then carefully “bump” the crankshaft in direction of rotation, at the same time observing the timing lights.
- (12) At the No. 1 firing position of the engine, the red light should go off indicating left main breaker opening. The right main breaker, monitored by the green light, must open within ± 2 engine degrees of the No. 1 firing position.
- (13) Repeat steps (9) thru (11) until the condition described in paragraph (12) is obtained.
- (14) Complete tightening of the magneto securing clamps by torquing to 150 in.-lbs.
- (15) Recheck timing once more and if satisfactory disconnect timing light. Remove adapter leads.
- (16) Reinstall plugs in timing inspection holes and torque 12-15 in.-lbs.
- (17) Install the harness leads as shown in Figure 5-1 to spark plug and connect switch lead to proper terminal.

NOTE

Some timing lights operate in the reverse manner as described. The light comes on when the breaker points open. Check your timing light instructions.

- d. *Internal Timing – Dual Magneto* – Check the magneto internal timing and breaker synchronization in the following manner.
 - (1) *Main Breakers* – Connect the timing light negative lead to any unpainted surface of the magneto. Connect one positive lead to the left main breaker terminal and the second positive lead to the right main breaker terminal.
 - (2) Back the engine up a few degrees and again bump forward toward number one cylinder firing position while observing timing lights. Both lights should go out to indicate opening of the main breakers, when the timing pointer is indicating within the width of the “L” or “R” mark. If breaker timing is incorrect, loosen breaker screws and correct. Retorque breaker screws to 20 to 25 in.-lbs.

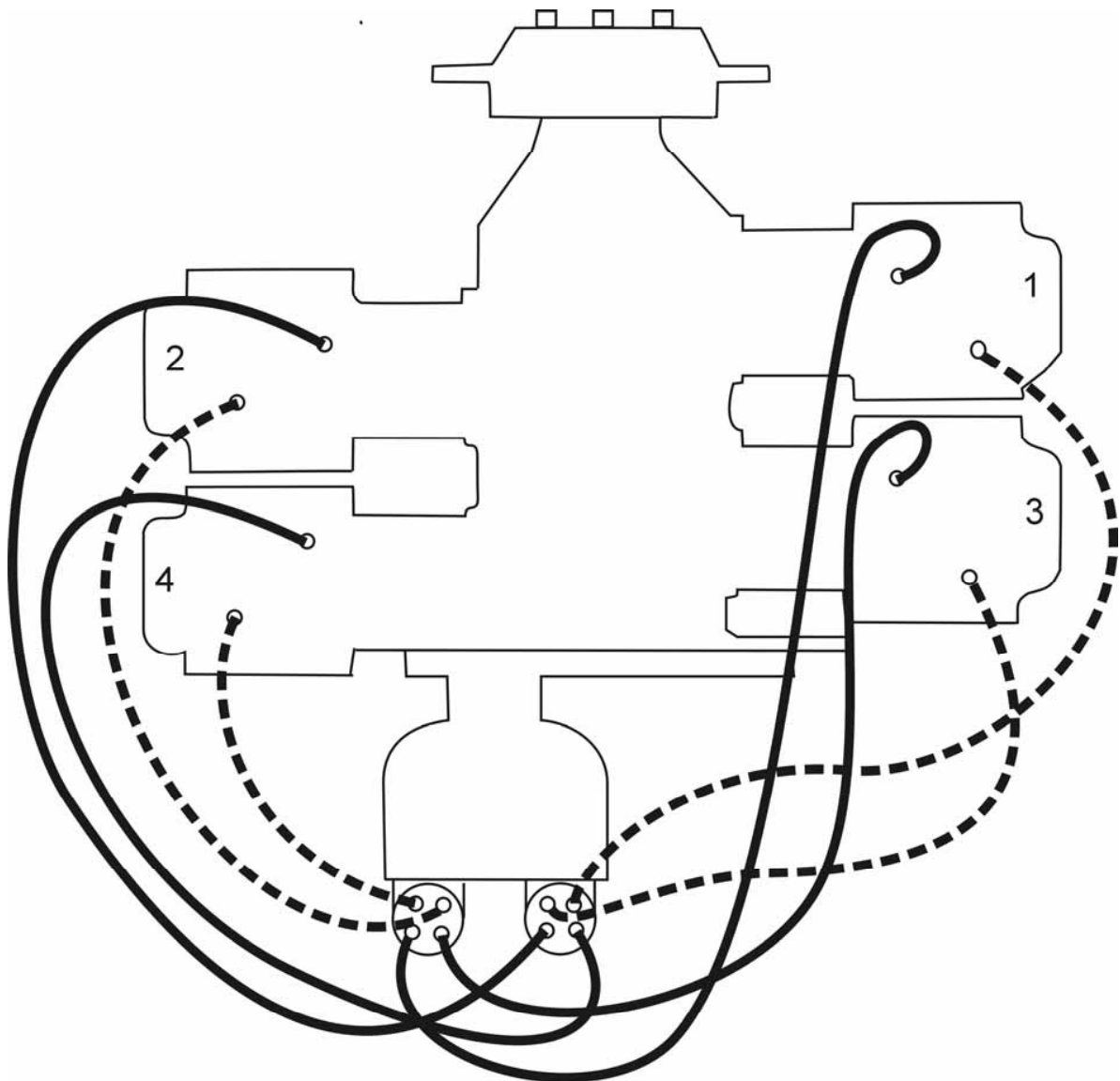

Figure 5-1. Ignition Wiring Diagram – Dual Magneto

- (3) *Retard Breaker* – Remove timing light leads from the main breaker terminals. Attach one positive lead to retard breaker terminal, and second positive lead to the tachometer breaker terminal, if used.
- (4) Back the engine up a few degrees and again bump forward toward number one cylinder firing position until pointer is aligned with 15° retard timing mark. See Figure 5-2. Retard breaker should just open at this position.
- (5) If retard timing is not correct, loosen cam securing screw and turn the retard breaker cam as required to make retard breaker open per paragraph d(4). Retorque cam screw to 16 to 20 in.-lbs.

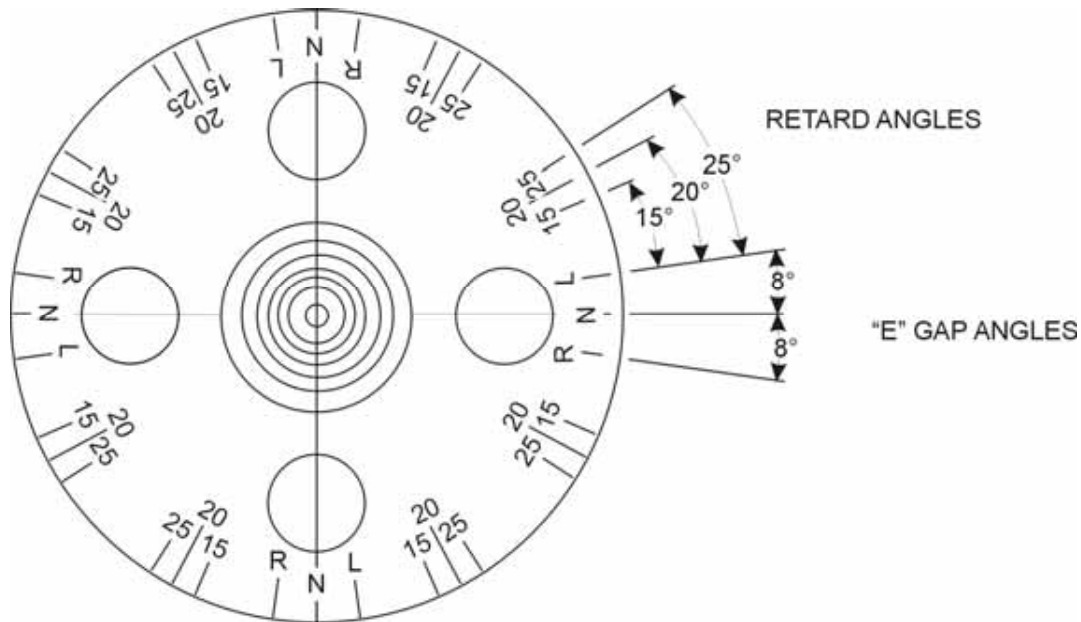

Figure 5-2. Timing Marks on Rotating Magneto

- (6) Observe the tachometer breaker is opened by the cam lobe. No synchronization of this breaker is required.
 - (7) Check action of impulse coupling (D-2000 series only). With the ignition switch off observe breaker cam end of rotor while manually cranking engine through a firing sequence. Rotor should alternately stop and then (with an audible snap) be rotated rapidly through a retard firing position.
- e. *Alternator Output* – The alternator should be checked to determine that the specified voltage and current is being obtained.

2. FUEL SYSTEM.

- a. *Repair of Fuel Leaks* – In the event a line or fitting in the fuel system is replaced, only a fuel soluble lubricant, such as clean engine oil or Loctite Hydraulic Sealant may be used. Do not use any other form of thread compound.
- b. *Carburetor Fuel Inlet Screen Assembly* – Remove the assembly and check the screen for distortion or openings in the strainer. Replace for either of these conditions. Clean screen assembly in solvent and dry with compressed air and reinstall. The fuel inlet screen assembly is tightened to 35-40 in.-lbs.
- c. *Fuel Grades and Limitations* – The recommended aviation grade fuel for the subject engines is listed in Section 3, item 9.

In the event that the specified fuel is not available at some locations, it is permissible to use higher octane fuel. Fuel of a lower octane than specified is not to be used. Under no circumstances should automotive fuel be used (regardless of octane rating).

NOTE

It is recommended that personnel be familiar with the latest revision of Service Instruction No.1070 regarding specified fuel for Lycoming engines.

- d. *Air Intake Ducts and Filter* – Check all air intake ducts for dirt or restrictions. Inspect and service air filters as instructed in the airframe manufacturer's handbook. Replace any filter or air duct that shows signs of deterioration or collapse.
- e. *Idle Speed and Mixture Adjustment* –
 - (1) Start the engine and warm up in the usual manner until oil and cylinder head temperatures are normal.
 - (2) Check magnetos. If the "mag-drop" is normal, proceed with idle adjustment.
 - (3) Set throttle stop screw so that the engine idles at the airframe manufacturer's recommended idling RPM. If the RPM changes appreciably after making idle adjustment during the succeeding steps, readjust the idle speed to the desired RPM.
 - (4) When the idling speed has been stabilized, move the cockpit mixture control lever with a smooth, steady pull toward the "Idle Cut-Off" position and observe the tachometer for any change during the leaning process. Caution must be exercised to return the mixture control to the "Full Rich" position before the RPM can drop to a point where the engine cuts out. An increase of more than 50 RPM while "leaning out" indicates an excessively rich idle mixture. An immediate decrease in RPM (if not preceded by a momentary increase) indicates the idle mixture is too lean.

If the above indicates that the idle adjustment is too rich or too lean, turn the idle mixture adjustment in the direction required for correction, and check this new position by repeating the above procedure. Make additional adjustments as necessary until a check results in a momentary pick-up of approximately 50 RPM. Each time the adjustment is changed, the engine should be run up to 2000 RPM to clear the engine before proceeding with the RPM check. Make final adjustment of the idle speed adjustment to obtain desired idling RPM with closed throttle. The above method aims at a setting that will obtain maximum RPM with minimum manifold pressure. In case the setting does not remain stable, check the throttle linkage; any looseness in this linkage would cause erratic idling. In all cases, allowance should be made for the effect of weather conditions and field altitude upon idling adjustment.

3. LUBRICATION SYSTEM.

- a. *Oil Grades and Limitations* – Service the engine in accordance with the recommended grade oil as specified in Section 3, item 9.
- b. *Oil Suction and Oil Pressure Screens* – At each fifty hour inspection remove, inspect for metal particles, clean and reinstall.

NOTE

On installations employing external oil filters, the inspection of the oil suction screen is impractical at this time, but should be observed when lubricating oil is changed.

- c. *Oil Relief Valve (Non-Adjustable)* – The function of the oil pressure relief valve is to maintain engine oil pressure within specified limits. The valve, although not adjustable, may be controlled by the addition of a maximum of nine STD-425 washers under the cap to increase pressure or the use of a spacer (Lycoming P/N 73629 or 73630) to decrease pressure. A modification on later models has eliminated the need for the spacers. Particles of metal or other foreign matter lodged between the ball and seat will result in faulty readings. It is advisable, therefore, to disassemble, inspect and clean the valve if excessive pressure fluctuations are noted.
- d. *Oil Relief Valve (Adjustable)* – The adjustable oil relief valve enables the operator to maintain engine oil pressure within the specified limits. If the pressure under normal operating conditions should consistently exceed the maximum or minimum specified limits, adjust the valve as follows.

With the engine warmed up and running at approximately 2000 RPM, observe the reading on the oil pressure gauge. If the pressure is above maximum or below minimum specified limits, stop engine and screw the adjusting screw out to decrease pressure and in to increase pressure. Depending on installation, the adjusting screw may have only a screw driver slot and is turned with a screw driver; or may have the screw driver slot plus a pinned .375-24 castellated nut and may be turned with either a screw driver or a box wrench.

4. *CYLINDERS*. Although the complete procedure for disassembly and reassembly is given here, it is recommended that, as a field operation, cylinder maintenance be confined to replacement of the entire assembly. Valve replacement should be undertaken only as an emergency measure.

- a. *Removal of Cylinder Assembly* –
- (1) Remove exhaust manifold.
 - (2) Remove rocker box drain tube, intake pipe, baffle and any clips that might interfere with the removal of the cylinder.
 - (3) Disconnect ignition cables and remove spark plugs.
 - (4) Remove rocker box cover and rotate crankshaft until piston is approximately at top center of the compression stroke. The approximate position may be located by observing top of piston through the spark plug hole and also observing that both valves are in the closed position.
 - (5) Remove the 5/16 x 24 self-locking nut. Thus remove the valve rocker, valve rocker fulcrum shim and rotator from exhaust valve.

NOTE

Do not lose shim when valve rocker fulcrum is removed from cylinder head.

- (6) Remove push rods by grasping ball end and pulling rod out of shroud tube. Detach shroud tube spring and lock plate and pull shroud tubes through holes in cylinder head.

NOTE

The hydraulic tappets, push rods, rocker arms and valves must be assembled in the same location from which they were removed.

- (7) Remove cylinder base nuts, then remove cylinder by pulling directly away from crankcase. Be careful not to allow the piston and connecting rod to drop against the crankcase as the piston leaves the cylinder.
- b. *Removal of Valves and Valve Springs from Cylinder* – Place the cylinder over a block of wood so as to hold the valves in a closed position. Compress the valve springs using the valve spring compressor. Remove the split keys from the end of the valve stem. The valve springs and valve spring seats may now be removed from the cylinder head. Hold the valve stems so that the valves will not fall out and remove the cylinder from the holding block. The valves may now be removed from the inside of the cylinder.
- c. *Removal of Piston from Connecting Rod* – Remove the piston pin plugs. Insert piston pin puller through piston pin, assemble puller nut; then proceed to remove piston pin. Do not allow connecting rod to rest on the cylinder pad of the crankcase. Support with heavy rubber bands, discarded cylinder base oil ring seals or any other method.
- d. *Removal, Disassembly, Cleaning, Inspection and Reassembly of Hydraulic Lifters* –
- (1) Lifter can be withdrawn by fingers.
 - (2) Being careful not to scratch socket, insert a screw driver into lifter and push. This will force the trapped oil out of the vent hole and release the pressure on the circlip.
 - (3) Remove and discard the circlip.

CAUTION

UPON RELEASE, CIRCLIP MAY SPRING UP WITH GREAT FORCE. BE CAREFUL!

- (4) Remove the spring, plunger and socket from the lifter and clean the parts and the lifter body in solvent. Inspect the lifter body for the following imperfections.

Spalling – If the face of the lifter shows small nicks or indentations near the center of the face, it is considered pitted or spalled. The pitting will constitute small irregular holes, not to be confused with Rockwell hardness check marks which are round and even. The area covered by spalling will vary with different lifters, but regardless of the degree, the lifter must be replaced.

Scoring – The lifter face is scored when small scratch like lines are found on the surface. These marks are usually found near the outer edge of the face and will appear to radiate from the center. Other scoring marks may be present and extend to the center of the lifter face. Any lifter, with this condition in evidence, must be replaced.

Face Wear – The operation of the lifter provides that the lifter rotates during wiping operation of the cam. This will form a groove, or path. This path will extend all the way across the face and deeper penetrations will be noted at the center of the face. If the wear is excessive, it will be noticeable to the touch if the fingernail is rubbed across the lifter face. This condition requires replacement of the lifter body.

- (5) Reassemble the spring, plunger and socket into the body and secure with a new circlip.

NOTE

The lifter must be perfectly dry to obtain proper dry tappet clearance.

e. *Assembly of Valves in Cylinder –*

- (1) Prelubricate valve stems and interior of valve guides with Molytex Grease O or equivalent and insert each valve stem in its respective guide. Hold valve stems to prevent falling from cylinder.
- (2) Place cylinder over a wood block so that the valves are held against the seats and assemble to lower spring seat, auxiliary valve spring and outer valve spring over the valve stem and guide. Place the upper spring seat on top of the springs.

NOTE

When installing valve springs, place the dampener end of spring (close wound coils marked with dye or lacquer) toward the cylinder.

Using a valve spring compressor (Service Tool ST-419) compress the valve springs and place the split keys in the groove around the upper end of the valve stem. Slowly release the pressure on the valve spring compressor and allow the upper spring seat to lock itself in place around the valve keys.

f. *Assembly of Cylinder and Related Parts –* Rotate the crankshaft so that the connecting rod of the cylinder being assembled is at the top center position and both tappets are on the base circle of the cam lobe. They can be checked by rocking the crankshaft over center. The tappet should not move at this position.

- (1) Install lifter assembly in its respective position in the crankcase.
- (2) Assemble piston with rings so that the cylinder number stamped on the piston pin boss is toward the front of the engine. The piston pin should be a hand push fit. If difficulty is experienced in inserting the piston pin, it is probably caused by carbon or burrs in the piston pin hole. Inspect and correct any problem that hinders the installation of the piston pin. During assembly, always use a generous quantity of oil, both in the piston pin hole and on the piston pin.
- (3) Assemble one piston pin plug at each end of the piston pin and place a new rubber oil seal ring around the cylinder skirt. Coat piston and rings and the inside of the cylinder generously with oil.
- (4) Using a piston ring compressor, assemble the cylinder over the piston so that the intake and exhaust ports are at the bottom of the engine. Push the cylinder all of the way on, catching the ring compressor as it is pushed off.

NOTE

Before installing cylinder hold-down nuts, lubricate crankcase thru-stud threads with any one of the following lubricants, or combination of lubricants.

1. 90% SAE 50W engine oil and 10% STP.
2. Parker Thread Lube.
3. 60% SAE 30 engine oil and 40% Parker Thread Lube.

- (5) Install cylinder base hold-down nuts and tighten as directed in the following steps.

NOTE

At any time a cylinder is replaced, it is necessary to retorque the thru-studs on the cylinder on the opposite side of the engine.

- (a) Tighten the ½ inch hold-down nuts to 300 in.-lbs. (25 ft.-lbs.) torque, using the sequence beginning with the top right nut and proceeding clockwise.
- (b) Using the same sequence tighten hold-down nuts to 600 in.-lbs. (50 ft.-lbs.) torque.
- (c) Tighten 3/8 inch hold-down nut to 300 in.-lbs. (25 ft.-lbs.) torque. Sequence of tightening is optional.
- (d) As a final check, hold the torque wrench on each nut, at the proper torque, for about five seconds. If the nut does not turn, it may be presumed to be tightened to correct torque.

CAUTION

AFTER ALL CYLINDER BASE NUTS HAVE BEEN TIGHTENED, REMOVE ANY SMALL NICKS IN THE CYLINDER FINS BY FILING OR BURRING.

- (6) Install a new large oil seal on the crankcase end of each shroud tube and fit a new small oil seal in the groove provided in the rocker box end of each shroud tube. Install each shroud tube through rocker box and seat the end firmly in the crankcase. Place a spring, a lock plate and nut over the stud provided in the rocker box and secure both shroud tubes in place. Bend the tang of the lock plate to prevent the nut and spring from loosening.
- (7) Assemble each push rod in its respective shroud tube, and assemble each fulcrum and rocker arm on its respective stud. Install a plain 5/16 x 24 nut to hold rocker in place. Before installing exhaust valve rocker, place rotator cap over end of exhaust valve stem.
- (8) Be sure that the piston is at top center of compression stroke and that both valves are closed. Check clearance between the valve stem tip and the valve rocker. In order to check this clearance, place the thumb of one hand on the valve rocker directly over the end of the push rod and push down so as to compress the hydraulic tappet spring. While holding the spring compressed, the valve clearance should be between .028 and .080 inch. If clearance does not come within these limits, add or subtract shim under fulcrum, as required to correct clearance. After clearance is set, remove plain 5/16 x 24 nut and install 5/16-24 self-locking nut on fulcrum stud. Torque nut to 150 in.-lbs.
- (9) Install inter-cylinder baffles, rocker box covers, intake pipes, rocker box drain tubes and exhaust manifold.

6. ALTERNATOR DRIVE BELT TENSION.

Check the tension of a new belt 25 hours after installation. Refer to the latest revision of Service Instruction No. 1129 for methods of checking alternator drive belt tension.

This Page Intentionally Left Blank.

LYCOMING 76 SERIES OPERATOR'S MANUAL

**SECTION 6
TROUBLE-SHOOTING**

	Page
Failure of Engine to Start.....	6-1
Failure of Engine to Idle Properly.....	6-2
Low Power and Uneven Running.....	6-2
Failure of Engine to Develop Full Power.....	6-3
Rough Engine.....	6-3
Low Oil Pressure.....	6-3
High Oil Temperature.....	6-4
Excessive Oil Consumption.....	6-4

This Page Intentionally Left Blank.

SECTION 6
TROUBLE-SHOOTING

Experience has proven that the best method of trouble-shooting is to decide on the various causes of a given trouble and then to eliminate causes one by one, beginning with the most probable. The following charts list some of the more common troubles, which may be encountered in maintaining engines; their probable causes and remedies.

1. TROUBLE-SHOOTING – ENGINE

TROUBLE	PROBABLE CAUSE	REMEDY
Failure of Engine to Start	Lack of fuel.	Check fuel system for leaks. Fill fuel tank. Clean dirty lines, strainers or fuel valves.
	Overpriming.	Leak ignition "off" and mixture control in "Idle Cut-Off", open throttle and "unload" engine by cranking for a few seconds. Turn ignition switch on and proceed to start in a normal manner.
	Defective spark plugs.	Clean and adjust or replace spark plugs.
	Defective ignition wire.	Check with electric tester, and replace any defective wires.
	Defective battery.	Replace with charged battery.
	Improper operation of magneto breaker.	Clean points. Check internal timing of magnetos. Check impulse action of dual breaker points. Check lead for grounding.
	Lack of sufficient fuel flow.	Disconnect fuel line and check fuel flow.
	Water in carburetor.	Drain carburetor.
	Internal failure.	Check oil screens for metal particles. If found, complete overhaul of the engine may be indicated.

**SECTION 6
TROUBLE-SHOOTING**

**LYCOMING 76 SERIES OPERATOR'S MANUAL
O-360**

TROUBLE	PROBABLE CAUSE	REMEDY
Failure of Engine to Idle Properly	Incorrect idle mixture.	Adjust mixture.
	Leak in induction system.	Tighten all connections in the induction system. Replace any parts that are defective.
	Incorrect idle adjustment.	Adjust throttle stop to obtain correct idle.
	Uneven cylinder compression.	Check condition of piston rings and valve seats.
	Faulty ignition system.	Check entire ignition system.
Low Power and Uneven Running	Insufficient fuel pressure.	Change fuel pump.
	Mixture too rich; indicated by sluggish operation, red exhaust flange at night. Extreme cases indicated by black smoke from exhaust.	Readjustment of carburetor by authorized personnel is indicated.
	Mixture too lean; indicated by overheating or backfiring.	Readjustment of carburetor by authorized personnel is indicated.
	Leaks in induction system.	Tighten all connections. Replace defective parts.
	Defective spark plugs.	Clean and gap or replace spark plugs.
	Improper fuel.	Fill tank with fuel of recommended grade.
	Magneto breaker points not working properly.	Clean points. Check internal timing of magnetos.
	Defective ignition wire.	Check wire with electric tester. Replace defective wire.
	Defective spark plug terminal connectors.	Replace connectors on spark plug wire.
Warped exhaust valve.	Check compression. Replace valve if necessary.	

TROUBLE	PROBABLE CAUSE	REMEDY
Failure of Engine to Develop Full Power	Leak in induction system.	Tighten all connections and replace defective parts.
	Throttle lever out of adjustment.	Adjust throttle lever.
	Improper fuel flow.	Check strainer, gauge and flow at the fuel inlet.
	Restriction in air scoop.	Examine air scoop and remove restrictions.
	Dirty air filter.	Replace filter.
	Muffler obstruction.	Repair or replace muffler.
	Improper fuel.	Drain and refill tank with recommended fuel.
Rough Engine	Faulty ignition.	Tighten all connections. Check system with tester. Check ignition timing.
	Cracked engine mount.	Replace or repair mount.
	Defective mounting bushings.	Install new mounting bushings.
	Defective spark plug or ignition lead.	Replace spark plug or ignition leads.
Low Oil Pressure	Uneven compression.	Check compression.
	Insufficient oil.	Fill to proper level with recommended oil.
	Chips or dirt in relief valve.	Remove and clean oil pressure relief valve.
	Leak in suction line or pressure line.	Check gasket between oil pump and accessory section.
	High oil temperature.	See "High Oil Temperature" in "Trouble" column.
	Defective pressure gauge.	Replace.
	Stoppage in oil pump intake passage.	Check line for obstruction. Clean suction strainer.

**SECTION 6
TROUBLE-SHOOTING**

**LYCOMING 76 SERIES OPERATOR'S MANUAL
O-360**

TROUBLE	PROBABLE CAUSE	REMEDY
High Oil Temperature	Insufficient air cooling.	Check air inlet and outlet for deformation or obstruction.
	Insufficient oil supply.	Fill to proper level with specified oil.
	Wrong grade of oil for season.	Replace with oil conforming to specifications.
	Clogged oil lines, strainers or cooler.	Remove and clean or replace oil line, strainers, or cooler.
	Excessive blow-by.	Usually caused by worn or stuck rings.
	Failing or failed bearings.	Examine sump for metal particles. If found, overhaul of engine is indicated.
	Defective temperature gauge.	Replace gauge.
Excessive Oil Consumption	Wrong seasonal grade of oil.	Fill tank with oil conforming to specifications.
	Failing or failed bearings.	Check sump for metal particles.
	Worn piston rings.	Install new rings.
	Incorrect installation of piston rings.	Install new rings.
	Failure of ring to seal (new nitrided cylinder).	Use mineral base oil. Climb to cruise altitude at full power and operate at 75% cruise power setting until oil consumption stabilizes.

LYCOMING 76 SERIES OPERATOR'S MANUAL

**SECTION 7
INSTALLATION AND STORAGE**

	Page
Preparation of Engine for Installation.....	7-1
General.....	7-1
Inspection of Engine Mounting	7-1
Oil and Fuel Line Connections	7-1
Propeller Installation.....	7-1
Preparation of Carburetors for Installation.....	7-2
Preparation of Engine for Storage	7-2
Installation Drawing	7-2

This Page Intentionally Left Blank.

SECTION 7

INSTALLATION AND STORAGE

1. PREPARATION OF ENGINE FOR INSTALLATION. Before installing an engine that has been prepared for storage, remove all dehydrator plugs, bags of desiccant and preservative oil from the engine. Preservative oil can be removed by removing the bottom spark plugs and turning the crankshaft three or four revolutions by hand. The preservative oil will then drain through the spark plug holes. Draining will be facilitated if the engine is tilted from side to side during the above operation. Preservative oil which has accumulated in the sump can be drained by removing the oil sump plug. Engines that have been stored in a cold place should be removed to an environment of at least 70°F (21°C) for a period of 24 hours before preservative oil is drained from the cylinders. If this is not possible, heat the cylinders with heat lamps before attempting to drain the engine.

After the oil sump has been drained, the plug should be replaced and safety-wired. Fill the sump with lubricating oil. The crankshaft should again be turned several revolutions to saturate the interior of the engine with the clean oil. When installing spark plugs, make sure that they are clean, if not, wash them in clean petroleum solvent. Of course, there will be a small amount of preservative oil remaining in the engine, but this can cause no harm. However, after twenty-five hours of operation, the lubricating oil should be drained while the engine is hot. This will remove any residual preservative oil that may have been present.

CAUTION

DO NOT ROTATE THE CRANKSHAFT OF AN ENGINE CONTAINING PRESERVATIVE OIL BEFORE REMOVING THE SPARK PLUG, BECAUSE IF THE CYLINDERS CONTAIN ANY APPRECIABLE AMOUNT OF THE MIXTURE, THE RESULTING ACTION, KNOWN AS HYDRAULICING, WILL CAUSE DAMAGE TO THE ENGINE. ALSO, ANY CONTACT OF THE PRESERVATIVE OIL WITH PAINTED SURFACES SHOULD BE AVOIDED.

General – Should any of the dehydrator plugs, if used, containing crystals of silica-gel or similar material be broken during their term of storage or upon their removal from the engine, and if any of the contents should fall into the engine, that portion of the engine must be disassembled and thoroughly cleaned before using the engine. The oil strainers should be removed and cleaned in gasoline or some other hydrocarbon solvent. The fuel drain screen located in the fuel inlet of the carburetor should also be removed and cleaned in a hydrocarbon solvent. The operator should also note if any valves are sticking. If they are, this condition can be eliminated by coating the valve stem generously with a mixture of gasoline and lubricating oil.

Inspection of Engine Mounting – If the aircraft is one from which an engine has been removed, make sure that the engine mount is not bent or damaged by distortion or misalignment as this can produce abnormal stress within the engine.

Oil and Fuel Line Connections – The oil and fuel line connections are called out on the accompanying installation drawings.

Propeller Installation – Consult the airframe manufacturer for information relative to propeller installation.

2. *PREPARATION OF CARBURETORS FOR INSTALLATION.*

Carburetors that have been prepared for storage should undergo the following procedures before being placed in service.

Carburetor – Remove the fuel drain plug and drain preservative oil. Remove the fuel inlet strainer assembly and clean in a hydrocarbon solvent. Reinstall the fuel drain plug and fuel inlet strainer assembly.

3. *PREPARATION OF ENGINE FOR STORAGE.*

Engines installed in aircraft that is inactive should be prepared for corrosion prevention as described in the latest revision of Service Letter No. L180.

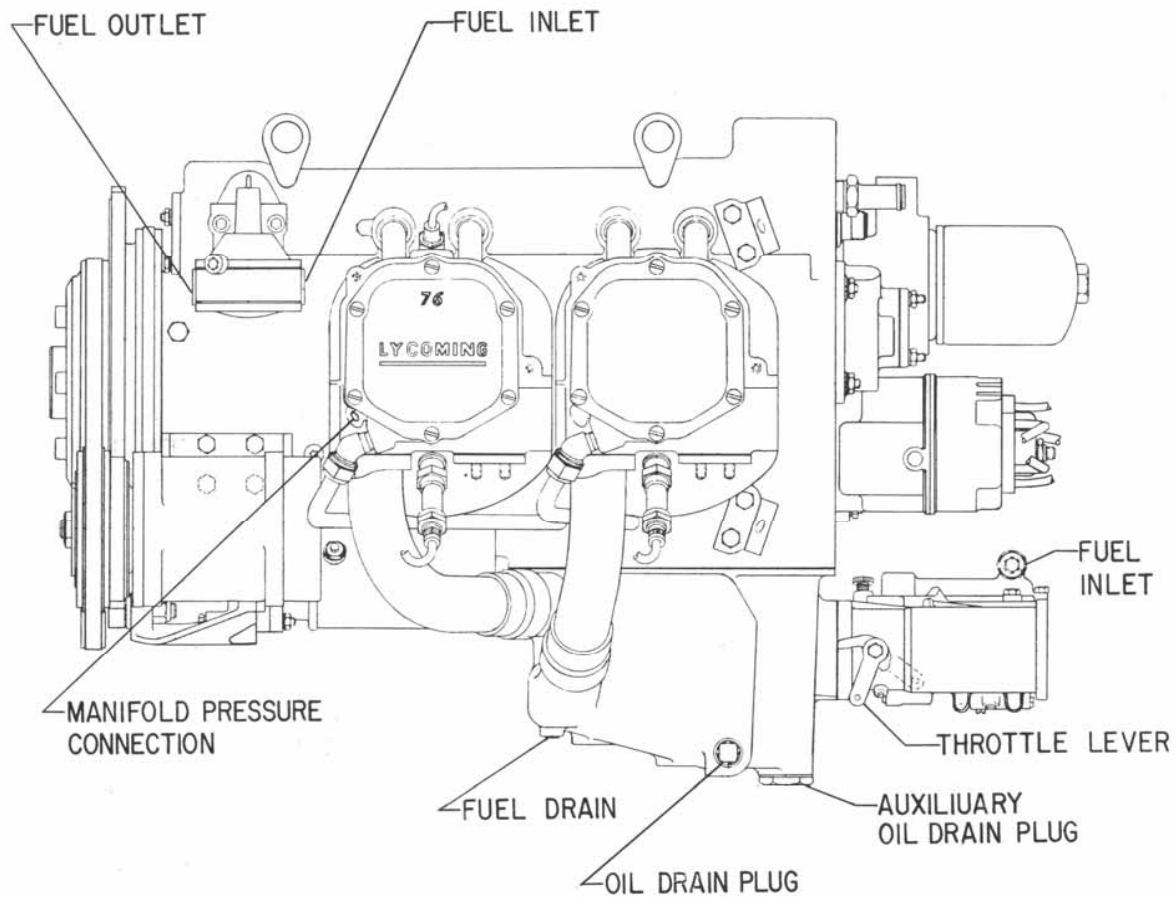

Figure 7-1. Installation Drawing –
Left Side View

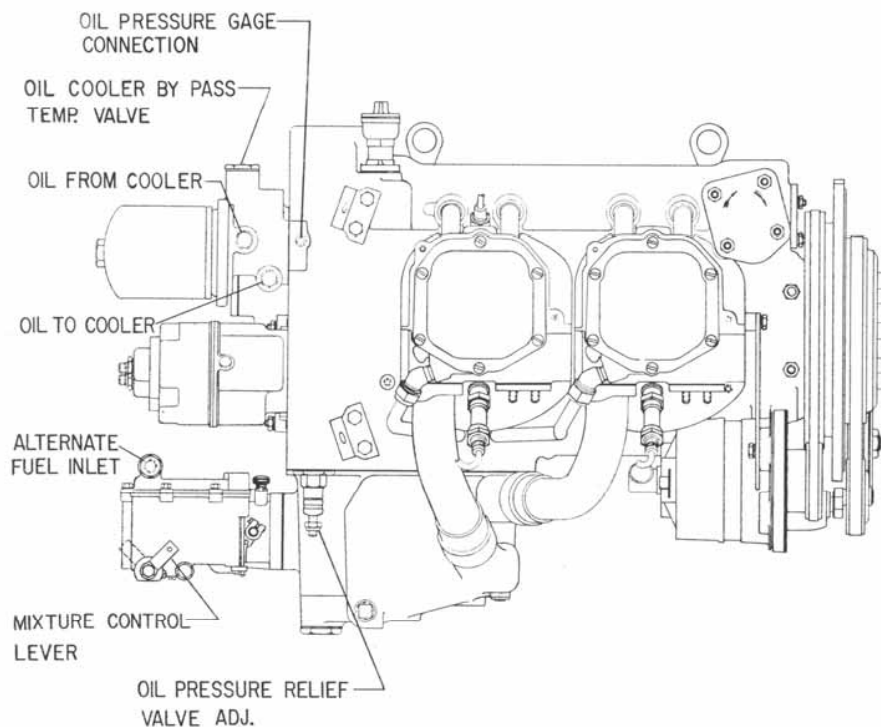

Figure 7-2. Installation Drawing –
Right Side View

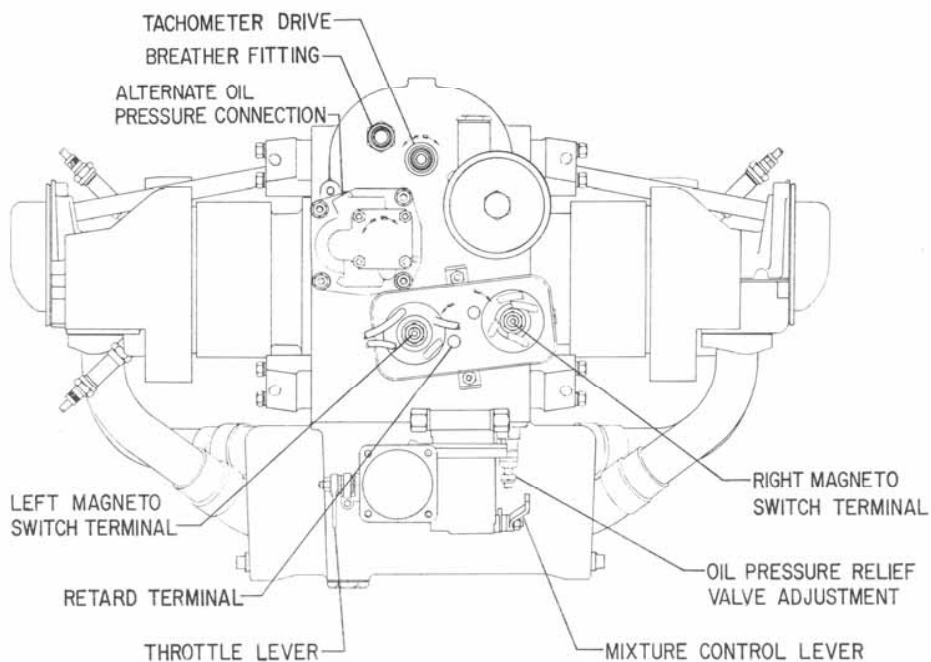

Figure 7-3. Installation Drawing –
Rear View

This Page Intentionally Left Blank.

LYCOMING **76** SERIES OPERATOR'S MANUAL

SECTION 8 TABLES

	Page
Table of Limits	8-1
Ground Run After Top Overhaul	8-2
Flight Test After Top Overhaul.....	8-3
Full Throttle HP at Altitude.....	8-4
Table of Speed Equivalents	8-4
Centigrade-Fahrenheit Conversion Table.....	8-5
Inch Fractions Conversion.....	8-6

This Page Intentionally Left Blank.

SECTION 8

TABLES

FOR TIGHTENING TORQUE RECOMMENDATIONS AND INFORMATION CONCERNING TOLERANCES AND DIMENSIONS THAT MUST BE MAINTAINED IN LYCOMING AIRCRAFT ENGINES, CONSULT THE LATEST REVISION OF TABLE OF LIMITS NO. SSP-1776.

FIXED WING ONLY

GROUND RUN AFTER TOP OVERHAUL
OR CYLINDER CHANGE WITH NEW RINGS
(DO NOT USE AFTER MAJOR OVERHAUL)

Type Aircraft _____
Registration No. _____
Aircraft No. _____
Owner _____
Engine Model _____ S/N _____
Date _____
Run-Up By _____

1. Avoid dusty location and loose stones.
2. Head aircraft into the wind.
3. All cowlings should be in place, cowl flaps open.
4. Accomplish ground run in full flat pitch.
5. Never exceed 200°F. oil temperature.
6. If cylinder head temperatures reach 400°F., shut down and allow engine to cool before continuing.

GROUND RUN

Time	RPM	MAP	Temperature				Pressure				Fuel Flow				
			L. oil	R. oil	L. cyl.	R. cyl.	L. oil	R. oil	L. fuel	R. fuel	L. carb.	R. carb.	Amb. Air	Left	Right
5 min	1000														
10 min	1200														
10 min	1300														
5 min	1500														
5 min	1600														
5 min	1700														
5 min	1800														

Mag. Check _____
Power Check _____
Idle Check _____

Adjustment Required _____
After Completion of Ground Run

1. Visually inspect engine(s)
2. Check oil levels

**FLIGHT TEST AFTER TOP OVERHAUL
OR CYLINDER CHANGE WITH NEW RINGS**

1. Test fly aircraft one hour.
2. Use standard power for climb, and at least 75% power for cruise.
3. Make climb shallow and at good airspeed for cooling.
4. Record engine instrument readings during climb and cruise.

Tested by _____

FLIGHT TEST RECORD

Time (Climb) Cruise	RPM	MAP	Temperature				Pressure				Temperature		Fuel Flow				
			L. oil	R. oil	L. cyl.	R. cyl.	L. oil	R. oil	L. fuel	R. fuel	L. carb	R. carb	Amb. Air	Left	Right		

Adjustment Required After Flight

After Test Flight.

1. Make careful visual inspection of engine(s).
2. Check oil level(s).
3. If oil consumption is excessive, (see operator's manual for limits), remove spark plugs and check cylinder barrels for scoring.

**FULL THROTTLE HP AT ALTITUDE
(Normally Aspirated Engines)**

Altitude Ft.	% S.L. H.P.	Altitude Ft.	% S.L. H.P.	Altitude Ft.	% S.L. H.P.
0	100	10,000	70.8	19,500	49.1
500	98.5	11,000	68.3	20,000	48.0
1,000	96.8	12,000	65.8	20,500	47.6
2,000	93.6	13,000	63.4	21,000	46.0
2,500	92.0	14,000	61.0	21,500	45.2
3,000	90.5	15,000	58.7	22,000	44.0
4,000	87.5	16,000	56.5	22,500	43.4
5,000	84.6	17,000	54.3	23,000	42.2
6,000	81.7	17,500	53.1	23,500	41.4
7,000	78.9	18,000	52.1	24,000	40.3
8,000	76.2	18,500	51.4	24,500	39.5
9,000	73.5	19,000	50.0	25,000	38.5

TABLE OF SPEED EQUIVALENTS

Sec./Mi.	M.P.H.	Sec./Mi.	M.P.H.	Sec./Mi.	M.P.H.
72.0	50	24.0	150	14.4	250
60.0	60	22.5	160	13.8	260
51.4	70	21.2	170	13.3	270
45.0	80	20.0	180	12.8	280
40.0	90	18.9	190	12.4	290
36.0	100	18.0	200	12.0	300
32.7	110	17.1	210	11.6	310
30.0	120	16.4	220	11.2	320
27.7	130	15.6	230	10.9	330
25.7	140	15.0	240	10.6	340

CENTIGRADE-FAHRENHEIT CONVERSION TABLE

Example: To convert 20°C to Fahrenheit, find 20 in the center column headed (F-C); then read 68.0°F in the column (F) to the right. To convert 20°F to Centigrade; find 20 in the center column and read -6.67°C in the (C) column to the left.

C	F-C	F	C	F-C	F
-56.7	-70	-94.0	104.44	220	428.0
-51.1	-60	-76.0	110.00	230	446.0
-45.6	-50	-58.0	115.56	240	464.0
-40.0	-40	-40.0	121.11	250	482.0
-34.0	-30	-22.0	126.67	260	500.0
-28.9	-20	-4.0	132.22	270	518.0
-23.3	-10	14.0	137.78	280	536.0
-17.8	0	32.0	143.33	290	554.0
-12.22	10	50.0	148.89	300	572.0
-6.67	20	68.0	154.44	310	590.0
1.11	30	86.0	160.00	320	608.0
4.44	40	104.0	165.56	330	626.0
10.00	50	122.0	171.11	340	644.0
15.56	60	140.0	176.67	350	662.0
21.11	70	158.0	182.22	360	680.0
26.67	80	176.0	187.78	370	698.0
32.22	90	194.0	193.33	380	716.0
37.78	100	212.0	198.89	390	734.0
43.33	110	230.0	204.44	400	752.0
48.89	120	248.0	210.00	410	770.0
54.44	130	266.0	215.56	420	788.0
50.00	140	284.0	221.11	430	806.0
65.56	150	302.0	226.67	440	824.0
71.00	160	320.0	232.22	450	842.0
76.67	170	338.0	237.78	460	860.0
82.22	180	356.0	243.33	470	878.0
87.78	190	374.0	248.89	480	896.0
93.33	200	392.0	254.44	490	914.0
98.89	210	410.0	260.00	500	932.0

**INCH FRACTIONS CONVERSIONS
Decimals, Area of Circles and Millimeters**

Inch Fraction	Decimal Equiv.	Area Sq. In.	MM Equiv.	Inch Fraction	Decimal Equiv.	Area Sq. In.	MM Equiv.
1/64	.0156	.0002	.397	1/2	.5	.1964	12.700
1/32	.0312	.0008	.794	17/32	.5312	.2217	13.494
3/64	.0469	.0017	1.191	35/64	.5469	.2349	13.891
1/16	.0625	.0031	1.587	9/16	.5625	.2485	14.288
3/32	.0937	.0069	2.381	19/32	.5937	.2769	15.081
7/64	.1094	.0094	2.778	39/64	.6094	.2916	15.478
1/8	.125	.0123	3.175	5/8	.625	.3068	15.875
5/32	.1562	.0192	3.969	21/32	.6562	.3382	16.669
11/64	.1719	.0232	4.366	43/64	.6719	.3545	17.065
3/16	.1875	.0276	4.762	11/16	.6875	.3712	17.462
7/32	.2187	.0376	5.556	23/32	.7187	.4057	18.256
15/64	.2344	.0431	5.593	47/64	.7344	.4235	18.653
1/4	.25	.0491	6.350	3/4	.75	.4418	19.050
9/32	.2812	.0621	7.144	25/32	.7812	.4794	19.844
19/64	.2969	.0692	7.540	51/64	.7969	.4987	20.241
5/16	.3125	.0767	7.937	13/16	.8125	.5185	20.637
11/32	.3437	.0928	8.731	27/32	.8437	.5591	21.431
23/64	.3594	.1014	9.128	55/64	.8594	.5800	21.828
3/8	.375	.1105	9.525	7/8	.875	.6013	22.225
13/32	.4062	.1296	10.319	29/32	.9062	.6450	23.019
27/64	.4219	.1398	10.716	59/64	.9219	.6675	23.416
7/16	.4375	.1503	11.112	15/16	.9375	.6903	23.812
15/32	.4687	.1725	11.906	31/32	.9687	.7371	24.606
31/64	.4844	.1842	12.303	63/64	.9844	.7610	25.003